



Larsen's Vista Series Fire Extinguisher Cabinets

Submittal and Detail Sheet

PROJECT: _____
 MODEL NUMBER: _____
 ARCHITECT: _____
 DATE: _____

LOCATION: _____
 QUANTITY: _____
 CONTRACTOR: _____
 DISTRIBUTOR: **Hallmann Sales**

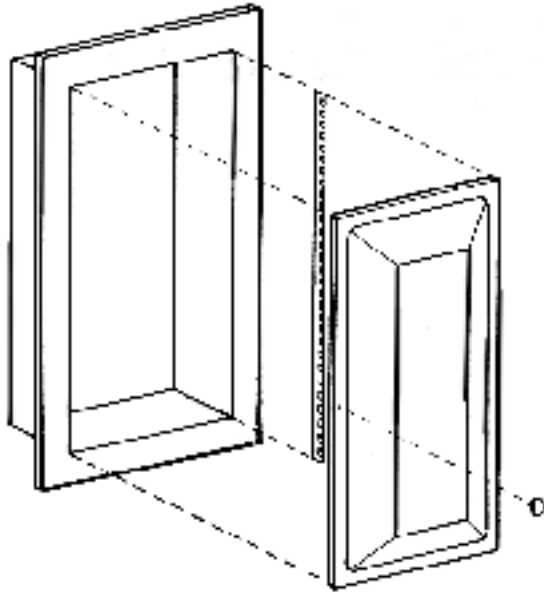

SPECIFICATIONS:

"VISTA" denotes a frameless door with color and design options as outlined below. The door is constructed of clear acrylic. The unique door design provides a 180° view of the fire extinguisher. The extinguisher is supported by the manufacturer's standard bracket.

BOX SPECIFICATION:

All recessed and surface-mounted steel cabinets have a white baked enamel box. Surface-mounted cabinets with aluminum trim have a box constructed entirely of clear or color anodized aluminum. Surface-mounted cabinets with stainless steel trim have a box constructed entirely of 304 stainless steel with a #4 finish.

TRIM SPECIFICATION:

The standard trim material is steel, and optional materials include both aluminum and stainless steel. All units come equipped with a chrome plated pull knob, magnetic catch, and continuous piano hinge. The standard VISTA bubble is clear acrylic and red acrylic is available as an option, if specified. Steel trims are one piece, constructed of cold-rolled steel with a standard finish of white baked enamel, which can be used as either a finish or prime coat. Aluminum trims are constructed of extruded aluminum with satin anodized finish. Clear anodized is standard, and a wide selection of optional color anodized finishes is available. To specify aluminum trim, use the prefix "AL" before the cabinet model number. Stainless steel trims are one piece, constructed of #4 finish, 304 stainless steel. To specify stainless steel trim, use the prefix "SS" before the cabinet model number.

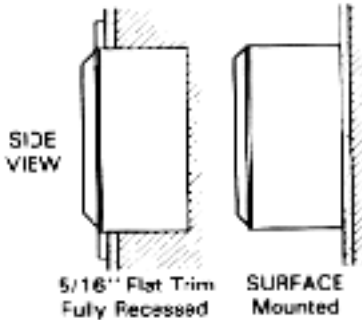

- | | | |
|------------------------------------------------|------------------------------------------------|------------------------------------------|
| TRIM MATERIAL | DOOR COLORS: | TRIM PROJECTION |
| <input type="checkbox"/> Steel | <input type="checkbox"/> Clear (Standard) | <input type="checkbox"/> Flat |
| <input type="checkbox"/> Aluminum (AL) | <input type="checkbox"/> Red | <input type="checkbox"/> Surface-Mounted |
| <input type="checkbox"/> Stainless (SS) | <input type="checkbox"/> Other (specify) _____ | |
| <input type="checkbox"/> Other (specify) _____ | | |

DIMENSIONS

Model Number	Trim Style and Projection	Inside Box Dimensions H x W x D	Outside Trim Dimensions H x W*	Rough Opening H x W x D	Recommended Extinguisher Capacity
V-2709 V-2709-SM	Rec. 5/16 Surface Mtd.	27x9-1/2x4 30-1/2x13x4	30-1/2x13 30-1/2x13	28x10-1/2x4 — —	MP2-1/2,MP5,DC2-1/2, DC5, MP5-A,MP6,MP10,DC6, DC10, HT2-1/2,HT5
V-3012 V-3012-SM	Rec. 5/16 Surface Mtd.	30x12x4 33-1/2x15-1/2x4	33-1/2x15-1/2 33-1/2x15-1/2	31x13x4 — —	PW2-1/2,MP20 DC20, WC-6L,HT11,HT15-1/2
FSV2709	Rec. 5/16	27x9-1/2x4	30-1/2x13	29-3/8x11-7/8x4-3/4	MP2-1/2,MP5,DC2-1/2, DC5, MP5-A,MP6,MP10,DC6, DC10, HT2-1/2,HT5
FSV3012	Rec. 5/16	30x12x4	33-1/2x15-1/2	32-3/8x14-3/8x4-3/8	PW2-1/2,MP20 DC20, WC-6L,HT11,HT15-1/2

*Deduct 3/4" from HxW dimensions for cabinets with aluminum trim

LARSEN'S MANUFACTURING COMPANY - www.larsensmfg.com

7421 Commerce Lane N.E., Mpls, MN 55432 Phone: (763) 571-1181 FAX: (763) 571-6900

FLORIDA DIVISION: 3130 N.W. 17th Street, Ft. Lauderdale, FL 33311 Phone: (954) 486-3325 FAX: (954) 486-3352

©2006 Larsen's Mfg. Co.