



Safety Technology International, Inc.  
2306 Airport Road • Waterford, Michigan 48327-1209  
Phone: 248-673-9898 • Fax: 248-673-1246  
Toll Free: 800-888-4784 • E-mail: info@sti-usa.com  
Web: www.sti-usa.com

Safety Technology International (Europe) Ltd.  
Unit 49G Pipers Road • Park Farm Industrial Estate • Redditch  
Worcestershire • B98 0HU • England • Tel: 44 (0) 1527 520 999  
Fax: 44 (0) 1527 501 999 • Freephone: 0800 085 1678 (UK only)  
E-mail: info@sti-europe.com • Web: www.sti-europe.com

#### NOTE:

If mounting to brick, block or concrete wall, drill 5/8" diameter holes 2" deep and insert lag shields.

If mounting to wood wall or wood stud, drill 9/32" diameter holes 1-1/2" deep.

#### INSTALLATION INSTRUCTIONS

1. Using needle-nose pliers remove both hinge pin snap rings.
2. Push out or lift out hinge pins and remove door.
3. Place enclosure on wall and mark top right hole position onto wall. Set enclosure aside.
4. Drill hole according to note above.
5. Insert lag screw into sealing washer. Place enclosure on wall and insert lag screw with sealing washer through enclosure and into drilled hole. Finger tighten only.
6. Allow enclosure to pivot and hang from lag screw.
7. Set a level on top of enclosure and level enclosure. Mark the remaining three mounting holes onto wall.
8. Allow enclosure to pivot and hang from lag screw and drill the remaining three holes.
9. Insert the remaining three lag screws with sealing washers through enclosure into wall and tighten all (4) lag screws.

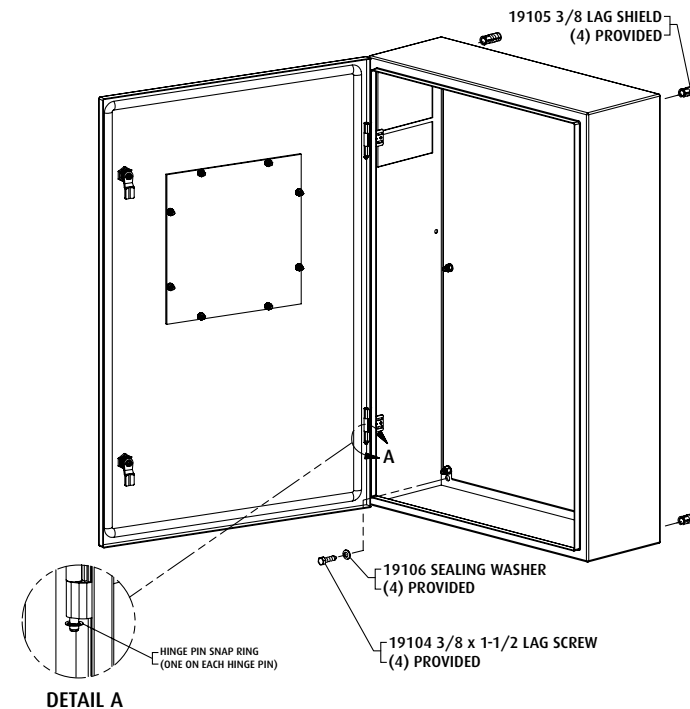
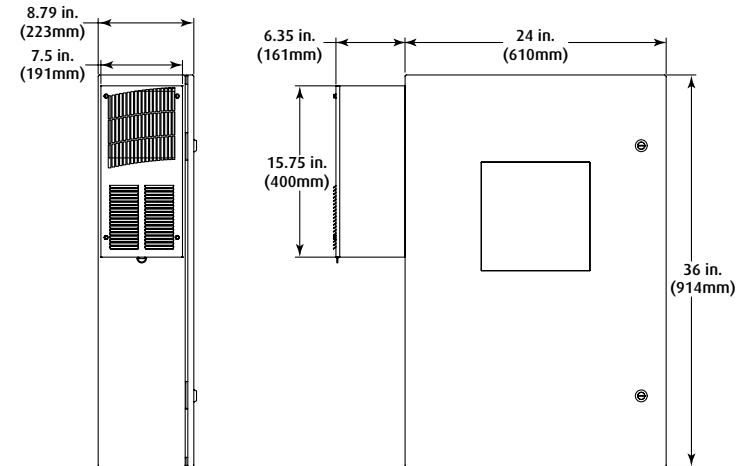

### STI-7560AC ENCLOSURE MOUNTING INSTRUCTIONS

All specifications and information shown were current as of publication and are subject to change without notice.



Safety Technology International, Inc.  
2306 Airport Road • Waterford, Michigan 48327-1209  
Phone: 248-673-9898 • Fax: 248-673-1246  
Toll Free: 800-888-4784 • E-mail: info@sti-usa.com  
Web: www.sti-usa.com

Safety Technology International (Europe) Ltd.  
Unit 49G Pipers Road • Park Farm Industrial Estate • Redditch  
Worcestershire • B98 0HU • England • Tel: 44 (0) 1527 520 999  
Fax: 44 (0) 1527 501 999 • Freephone: 0800 085 1678 (UK only)  
E-mail: info@sti-europe.com • Web: www.sti-europe.com

After enclosure has been mounted to the wall, the A/C unit can be mounted to the enclosure.

#### INSTALLATION NOTES

1. Read and understand instruction manual before mounting and operating A/C unit.
2. Install gasket provided on to A/C unit.
3. Insert power cord and wires through top cutout in enclosure.
4. Mount A/C unit to enclosure by resting EZ mount tabs on bottom cutout edge. This will hold A/C unit in place while bolts are inserted.
5. Insert the (4) 1/4 - 20 x 3/4 inch bolts with lock washers. Make sure the threads of all (4) bolts have engaged with the A/C unit before tightening.
6. Tighten the 4 bolts evenly.
7. Replace door, hinge pins and hinge pin snap rings.

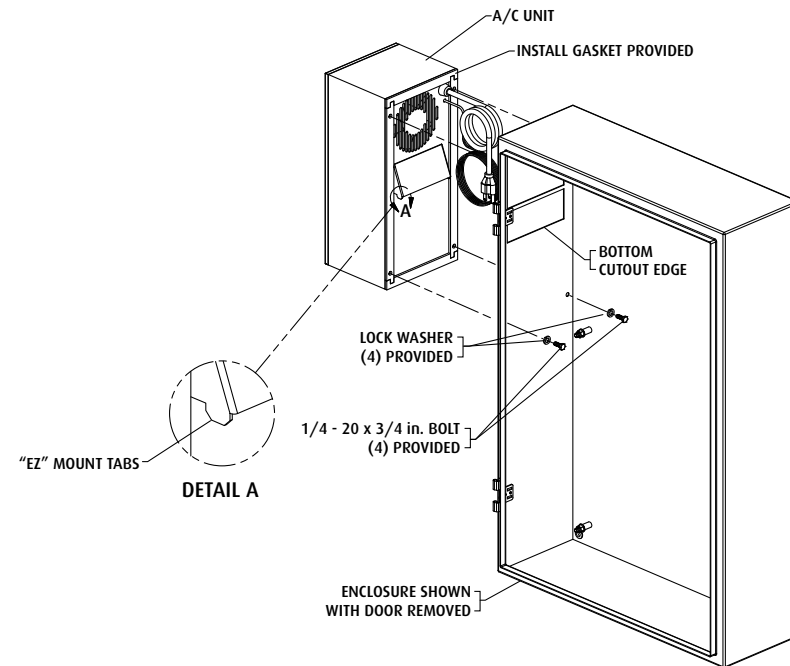
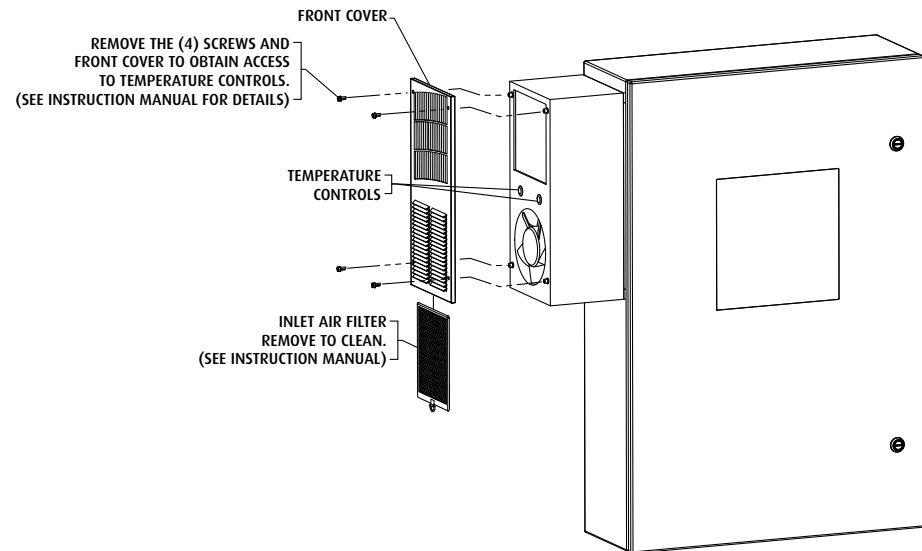

### STI-7560AC MOUNTING A/C UNIT INSTRUCTIONS

All specifications and information shown were current as of publication and are subject to change without notice.