

STI MINI THEFT STOPPER®

This Ingenious Device Protects Both Freestanding or Cabinet-Mounted Fire Extinguishers and Other Equipment

Here is an inexpensive yet highly effective way to protect fire extinguishers and a wide range of other fire fighting equipment from theft. The device is compact, highly effective, and extremely versatile. It does not interfere with fire fighting in any way. Also, the simplicity of design contributes to its high degree of reliability.

How It Works

For cabinets housing a fire extinguisher, fire hoses, sprinkler shutoff valves, guns, medicine, etc. Mini Theft Stopper is mounted next to the door or in the cabinet and its reed switch unit is mounted on the door jam. The matching magnet is mounted on the door near it and when the door is opened the device sounds a 105 dB warning horn.

For a freestanding fire extinguisher or other freestanding equipment, Mini Theft Stopper has available, a special clip that can be used in several ways. An extinguisher's pull pin may be routed through the holes in both prongs of the clip. The clip is then held in place by the extinguisher's seal and when the seal is broken to use the extinguisher, the alarm sounds. The steel clip can also be placed under any type of equipment. When lifted, the clip opens and the alarm sounds immediately.



STI-6255

Features

- Highly visible "stop sign" design discourages wrongful use of extinguisher.
- Sounds a powerful 105 dB warning horn when activated, drawing attention in a hurry.
- Two methods of operation—reed switch activation for cabinets and display cases and unique clip activation for fire extinguisher pins and other freestanding equipment.
- Deactivation pin provided for service by authorized personnel.
- Does not interfere with use of protected fire fighting equipment.
- 9 VDC alkaline battery is included.
- Compact design. It is 3.37 in. (86mm) in diameter and 1 in. (25mm) deep. Mounts easily next to extinguisher or in cabinet.
- Three minute automatic reset upon activation.
- Extremely cost-effective and easy to install.
- One year guarantee against breakage of ABS housing and on electronic components.
- Recommended operational range 32°F to 120°F (0°C to 49°C).
- Tough, ABS construction.



Safety Technology International, Inc.

2306 Airport Road • Waterford, Michigan 48327-1209

Phone: 248-673-9898 • Fax: 248-673-1246 • Toll Free: 800-888-4784 • E-mail: info@sti-usa.com • Web: www.sti-usa.com

Europe Branch Office • Unit 49G Pipers Road • Park Farm Industrial Estate • Redditch • Worcestershire • B98 0HU • England

Tel: 44 (0) 1527 520 999 • Fax: 44 (0) 1527 501 999 • Freephone: 0800 085 1678 (UK only) • E-mail: info@sti-europe.com • Web: www.sti-europe.com

STI MINI THEFT STOPPER®

Dimensions and Technical Information

Model Available

STI-6255 Mini Theft Stopper
SUB-65 Replacement Breakaway Tie Wraps (Qty. 5)

Product Information

Mini Theft Stopper has two versatile methods of activation. This flexibility of design and compact housing allows this multi-purpose unit to protect equipment or cabinets of virtually any kind without sacrificing performance.

REED SWITCH/MAGNET ACTIVATION

This method of activation is the reed switch and magnet which can be used to protect doors and cabinets, etc. The Mini Theft Stopper is mounted next to the door or in the cabinet and the reed switch mechanism on the door jam as shown at right. The magnet is mounted on the door so that when it is closed it is in close proximity to the reed switch. When opened, the alarm will immediately activate.

VERSATILE SPRING STEEL ACTIVATION

A special spring steel clip offers a variety of possibilities. The clip may be used to protect free-standing fire extinguishers by routing the extinguisher's pull pin through the holes in both prongs of the clip. The clip is then held in place by the extinguisher's breakaway seal. When the seal is broken to use the extinguisher, the alarm immediately sounds. The steel clip may also be placed under almost any type of equipment. When the protected device is lifted, the clip expands and the alarm will sound immediately. **NOTE:** If the extinguisher pin method is used, the State of California requires installation of pin seal by a licensed fire extinguisher contractor.

NOTE: Verify if Authority Having Jurisdiction requires licensed extinguisher technician to install. End user must verify the alarm and battery every six months and replace battery annually or as required.

SPECIFICATIONS

Housing	1/8 in. ABS
Power Source	9 VDC Alkaline
Warning Horn at 1 foot	105 dB
Operation	Steel Contact Clip Magnetic Reed
Dimensions	3.37 in. W x 1 in. D
Standby Current	None
Alarm Current	115 mA
Auto Reset	3 Minutes
Recommended Operating Temperature	32°F to 120°F (0°C to 49°C)

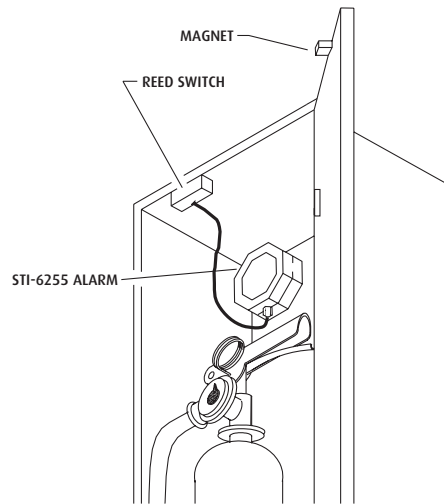

REED SWITCH ACTIVATION

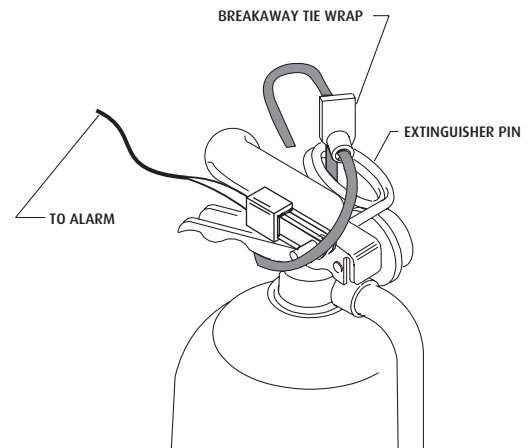
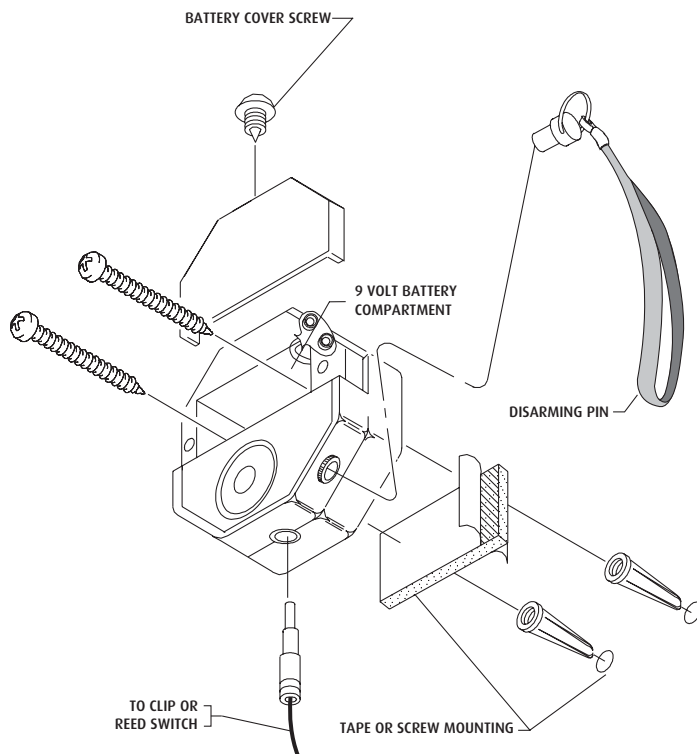

CLIP ACTIVATION