

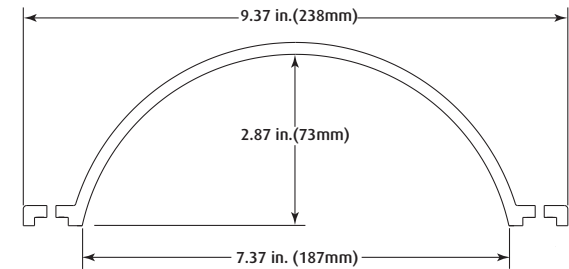

Safety Technology International, Inc.
2306 Airport Road • Waterford, Michigan 48327-1209
Phone: 248-673-9898 • Fax: 248-673-1246
Toll Free: 800-888-4784 • E-mail: info@sti-usa.com
Web: www.sti-usa.com

Safety Technology International (Europe) Ltd.
Unit 49G Pipers Road • Park Farm Industrial Estate • Redditch
Worcestershire • B98 0HU • England • Tel: 44 (0) 1527 520 999
Fax: 44 (0) 1527 501 999 • Freephone: 0800 085 1678 (UK only)
E-mail: info@sti-europe.com • Web: www.sti-europe.com

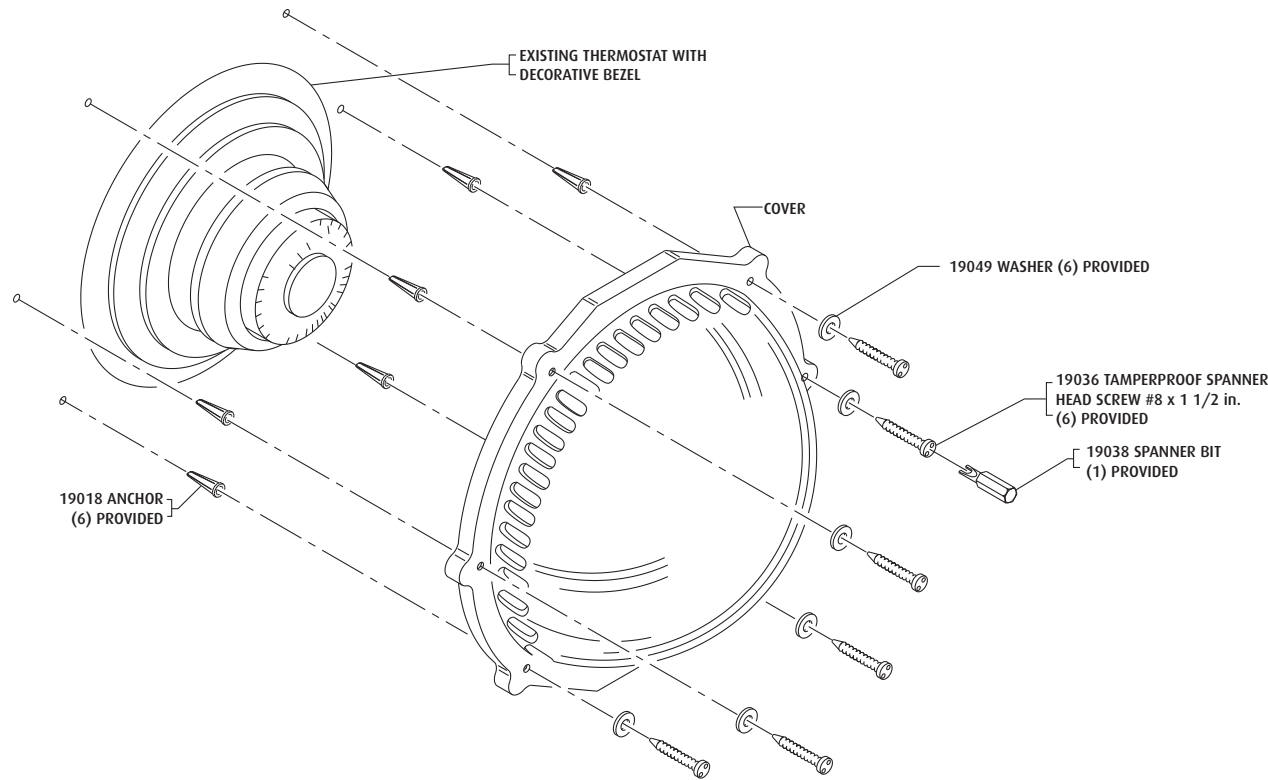

PRODUCT DIMENSIONS

INSTALLATION INSTRUCTIONS

1. Center protective cover over thermostat.
2. Using protective cover as template, mark and drill (6) 3/16 in. (4.7mm) diameter holes as shown.
3. Install the tamperproof fasteners using the supplied spanner bit.

CLEANING INSTRUCTIONS:

To clean cover, remove from wall. Rinse with water to remove abrasive dust and dirt. Wash with soap or mild detergent using a soft cloth (DO NOT SCRUB). Rinse once more, then dry with a soft cloth or chamois. To remove grease or wet paint, rub gently with a cloth wetted thoroughly with naphtha. Then wash and rinse. DO NOT USE RAZOR BLADES.

INSTALLATION OF STI-9115 TAMPERPROOF THERMOSTAT COVER

All specifications and information shown were current as of publication, and are subject to change without notice.

9115 APRIL2009

